

SMD CERAMIC (5x 3.2) 2P TYPE



Application of Crystal

- ▶ Radio communication
- ▶ Blue tooth
- ▶ Office automation equipment
- ▶ Digital camera
- ▶ Wireless Lan



Features

- ▶ 1.1mm thickness is equal to SMD-type IC
- ▶ Excellent reliability and environment capability
- ▶ High-density mounting-type SMD
- ▶ Excellent vibration resistance & shock resistance
- ▶ available
- ▶ Rohs compliant / Pb free



Electrical Specification

NO	Model	SMD CERAMIC (5x 3.2) 2P TYPE
1	Frequency Range	8.0 ~ 125.0 MHz
2	Frequency Tolerance at 25°C±2°C	±10 ~ ±50 ppm (TYP.)
3	Frequency Stability Over Operating Range	±10 ~ ±50 ppm (TYP.)
4	Operating Temp Range	-10°C~ +60°C, -20°C~ +70°C or customer requirement
5	Load Capacitance	6 pF ~ 32 pF, series or special
6	Shunt Capacitance	7 pF Max.
7	Drive Level	0.1uW ~ 1000uW(TYP.: 100uW)
8	Insulation Resistance	500MΩ min / DC 100V±15V
9	Oscillation Mode	Fundamental, 3rd & 5th overtone
10	Measure Instrument	S&A 250B
11	Aging Rate	±3ppm/year

Equivalent Series Resistance(ESR) VS Frequency

NO	Frequency (MHz)	Oscillation Mode	SMD CERAMIC (5x 3.2) 2P TYPE
1	8.0 ~10.0	Fundamental	120Ω MAX
2	10.0~12.0	Fundamental	80Ω MAX
3	12.1~25.0	Fundamental	60Ω MAX
4	25.1~52.0	Fundamental	40Ω MAX
5	45.1~125.0	3rd overtone	100Ω MAX

SMD CERAMIC (5x 3.2) 2P SIZE



Dimensions (mm):

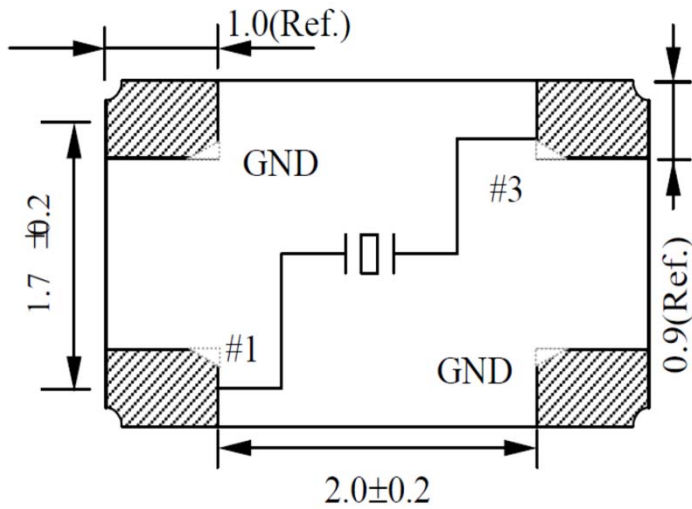
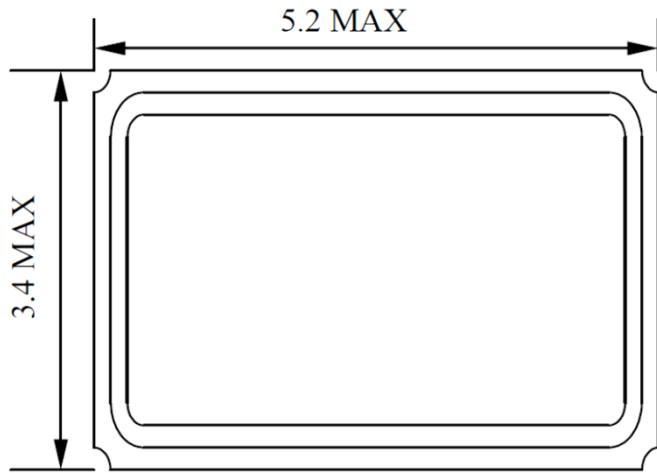

<TOP VIEW>

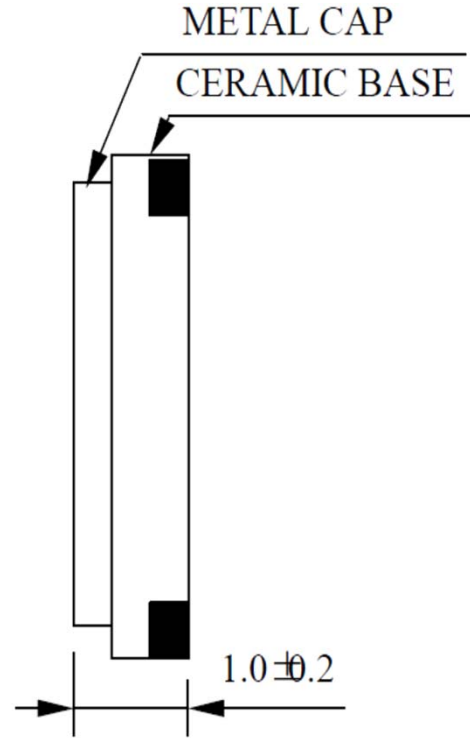

Recommended Land Pattern:

