

1000 Base-T Dual port LAN Transformer Module MODEL NO:HA4809SG

Feature:



Designed for long haul Gigabit Ethernet 100/1000Base-TX,full duplex applications
 Supports 8 pairs of category 5 UTP cable
 Suitable for End-span POE 720mA current capability applications Meets all IEEE802.3 at Standards
 Primary inductance(Lp):350 μ H Min (100KHz ,100mV ,8mA)
 SMD Environmental: Designed to meet IR 235 $^{\circ}$ C 1 minute
 Storage Temprange:-20 $^{\circ}$ C To +85 $^{\circ}$ C
 HI-POT:4300VAC 1mA 1Sec

Electrical Specifications at 25 $^{\circ}$ C – Operating Temprange: 0 $^{\circ}$ C To +70 $^{\circ}$ C

Part Number	Transformer Turns ratio ($\pm 3\%$) Receive Transmit	Insertion Loss (dB TYP) 1~100MHz	Crosstalk (dB TYP) 1~100(MHz)	Return loss (dB TYP) 1~30/40/50/60~80/100(MHz)	DCMR (dB TYP) 30/60/100 (MHz)
HA4809SG	1:1 1CT:1CT	-1.0	-30	-18/ -14.4/ -13.1/-12/-10	-30

Dimension : mm

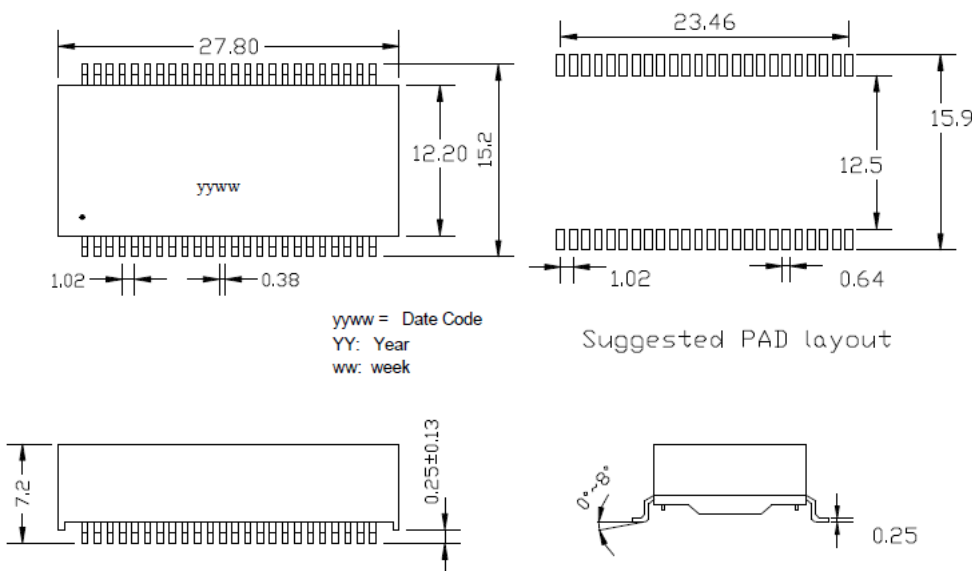

Schematics :

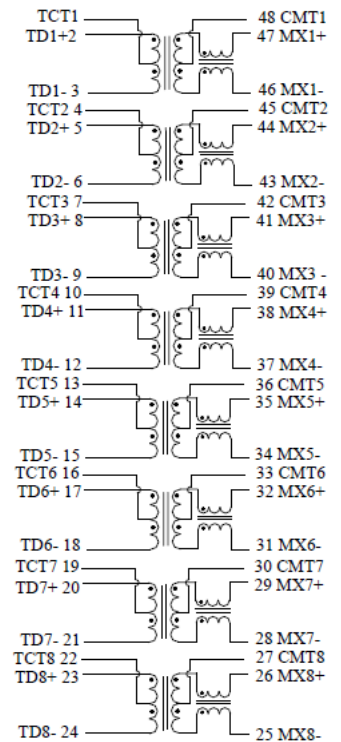

Data sheet subject to change without notice Unless otherwise specified,all tolerance are ± 0.25 mm