

LAN Transformer Module

LAP-17E241P7D8

1. Features

1. Low profile, small footprint saves board space and height
2. Design for 2.5G ethernet application
3. Pin to Pin compatibility with LAN transformer
4. Operating temperature range: -40°C to +105°C.
5. Storage temperature range: -40°C to +105°C.
6. 100% Lead (Pb)-Free and RoHS compliant.



2. Applications

1. 2.5G Base-T, Single Port, Low profile Modules w/Surge Protection (24 Pin)
2. POE 802.3bt applications

3. Dimensions

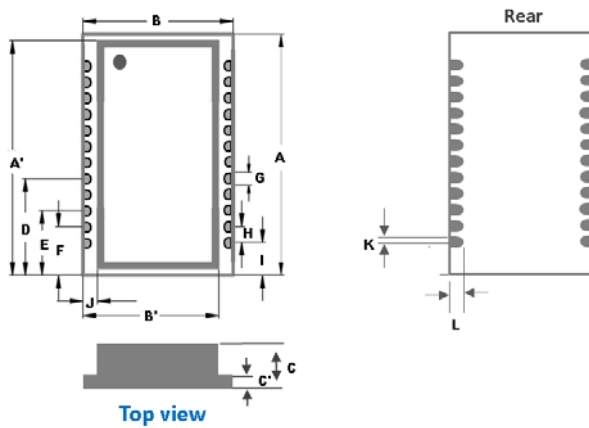

Size	A(mm)	A'(mm)	B(mm)	B'(mm)	C(mm)	C'(mm)
	17.53	17.03	14.6	13.92	4.5 max	0.8
	D(mm)	E(mm)	F(mm)	G(mm)	H(mm)	I(mm)
	6.86	4.32	3.05	0.4	1.27	1.78
	J(mm)	K(mm)	L(mm)			
0.67	0.2	1.1				

Tolerance: XX.X0 +/-0.25(mm)

0.XX +/-0.05(mm)

Recommend PC Board Pattern

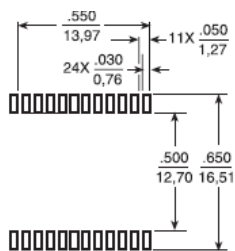

Units: mm (inch) Tolerance: XX.X0 +/-0.25 (0.010)
0.XX +/-0.05 (0.002)

4. Part Numbering

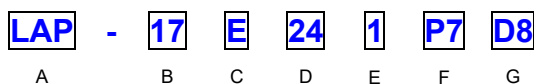

- A: Series C: Application E: Center tab G: Special
 B: Long D: Pin F: Pitch

5. Specification

Part Number	OCL (uH Min) @100KHz/0.1V with 11mA DC Bias	Insertion Loss (dB Max) 1~125MHz	Return Loss (dB min)		CMRR(dB Min)		Cross talk (dB min) 1~125MHz
			$1 \leq f \leq 40\text{MHz}$	$40 \leq f \leq 125\text{MHz}$	$1 < f \leq 30\text{MHz}$	$30 < f \leq 125\text{MHz}$	
LAP-17E241P7D8	120	-1.2	-20	$-20+15*\text{LOG}(f/40)$	-30	-25	-30

Note:

1. All test data referenced to 25°C ambient
2. Hi-Pot resistance of 1500 VAC for 1 minute
3. Recommended the design modules should be assembled on the second side.

6. Schematic

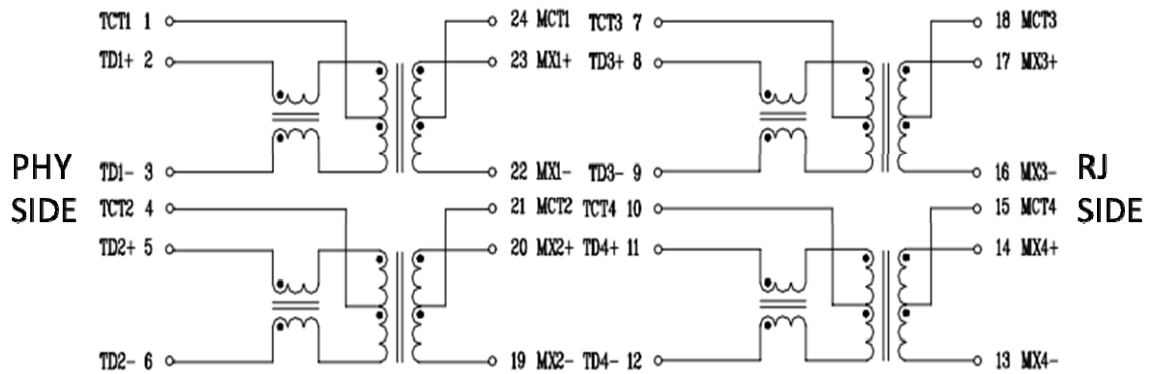

7. Pin Define

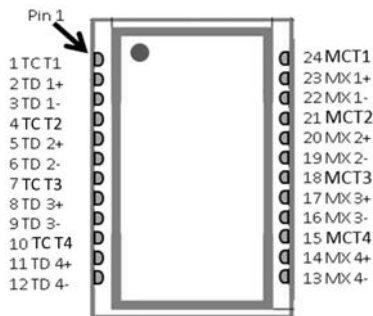

8. Reliability and Test Condition

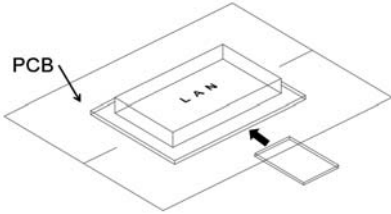
Item	Performance	Test Condition								
Insertion Loss	Refer to standard electrical characteristics list.	Agilent E5071C								
Return Loss										
Cross talk										
DCMR										
Operating Temperature	-40°C~+105°C (Including self - temperature rise)									
Storage Temperature	-40°C~+105°C (Product without taping)									
Life Test		Preconditioning: Run through IR reflow for 3 times. (IPC/JEDEC J-STD-020E Classification Reflow Profiles) Temperature : 105±2°C Duration : 1000±12hrs Measured at room temperature after placing for 24±2 hrs								
Humidity Resistance Test	Appearance : No damage. Insertion Loss : within spec. Return Loss : within spec.	Preconditioning: Run through IR reflow for 3 times. (IPC/JEDEC J-STD-020E Classification Reflow Profiles) Humidity : 85±2% R.H. Temperature : 85°C±2°C Duration : 1000hrs Min. Bead: with 100% rated current. Inductance: with 10% rated current. Measured at room temperature after placing for 24±2 hrs								
Thermal shock Test	Appearance : No damage. Insertion Loss : within spec. Return Loss : within spec.	Preconditioning: Run through IR reflow for 3 times. (IPC/JEDEC J-STD-020E Classification Reflow Profiles) Step1 : -40±2°C 30±5min Step2 : 25±2°C ≤0.5min Step3 : 105±2°C 30±5min Number of cycles : 500 Measured at room temperature after placing for 24±2 hrs								
Vibration Test		Preconditioning: Run through IR reflow for 3 times. (IPC/JEDEC J-STD-020E Classification Reflow Profiles) Oscillation Frequency: 10Hz~2KHz~10Hz for 20 minutes Equipment : Vibration checker Total Amplitude:10g Testing Time : 12 hours(20 minutes, 12 cycles each of 3 orientations)								
Solderability Test	More than 95% of bottom terminal electrode should be covered with solder.	a. Method B, 4 hrs @155°C dry heat @235°C±5°C Test time:5 +0/-0.5 seconds. b. Method D category 3. (steam aging 8hours ± 15 min)@ 260°C±5°C Test time: 30 +0/-0.5 seconds.								
Resistance To Solder Heat Test	Appearance : No damage.	Depth: completely cover bottom the termination <table border="1"> <thead> <tr> <th>Temperature(°C)</th> <th>Time(s)</th> <th>Temperature ramp/immersion and emersion rate</th> <th>Number of heat cycles</th> </tr> </thead> <tbody> <tr> <td>260 ±5 (solder temp)</td> <td>10 ±1</td> <td>25mm/s ±6 mm/s</td> <td>1</td> </tr> </tbody> </table>	Temperature(°C)	Time(s)	Temperature ramp/immersion and emersion rate	Number of heat cycles	260 ±5 (solder temp)	10 ±1	25mm/s ±6 mm/s	1
Temperature(°C)	Time(s)	Temperature ramp/immersion and emersion rate	Number of heat cycles							
260 ±5 (solder temp)	10 ±1	25mm/s ±6 mm/s	1							
Terminal Strength Test	<table border="1"> <tbody> <tr> <td>Series No.</td> <td>2(Kg)</td> </tr> <tr> <td>LAN</td> <td>1.0(min.)</td> </tr> </tbody> </table>	Series No.	2(Kg)	LAN	1.0(min.)	<p>With the component mounted on a PCB with the device to be tested, apply a force to the side of a device being tested. This force shall be applied for 60 +1 seconds. Also the force shall be applied gradually as not to apply a shock to the component being tested.</p> 				
Series No.	2(Kg)									
LAN	1.0(min.)									

9. Soldering and Mounting

9-1. Soldering

Mildly activated rosin fluxes are preferred. TAI-TECH terminations are suitable for re-flow soldering systems. If hand soldering cannot be avoided, the preferred technique is the utilization of hot air soldering tools.

9-1.1 IR Soldering Reflow:

Recommended temperature profiles for lead free re-flow soldering in Figure 1. Table 1.1&1.2 (J-STD-020E)

9-1.2 Soldering Iron:

Products attachment with a soldering iron is discouraged due to the inherent process control limitations. In the event that a soldering iron must be employed the following precautions are recommended. (Figure 2.)

- Preheat circuit and products to 150°C
- 350°C tip temperature (max)
- Use a 20 watt soldering iron with tip diameter of 1.0mm
- 1.0mm tip diameter (max)
- Limit soldering time to 4~5 sec.

Fig.1 IR Soldering Reflow

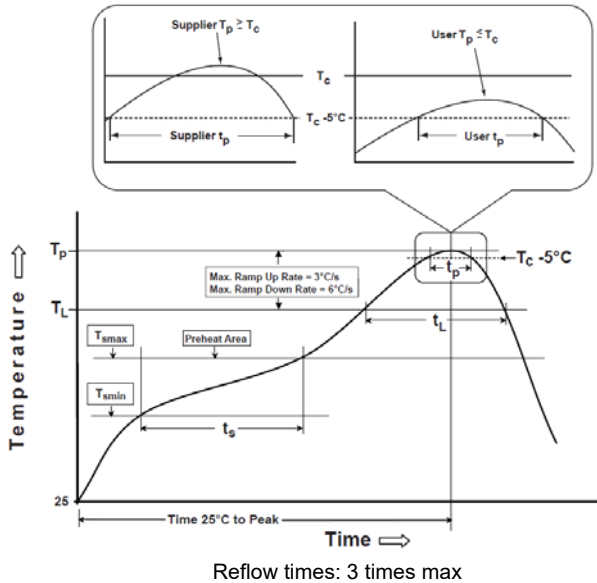

Fig.2 Iron soldering temperature profiles

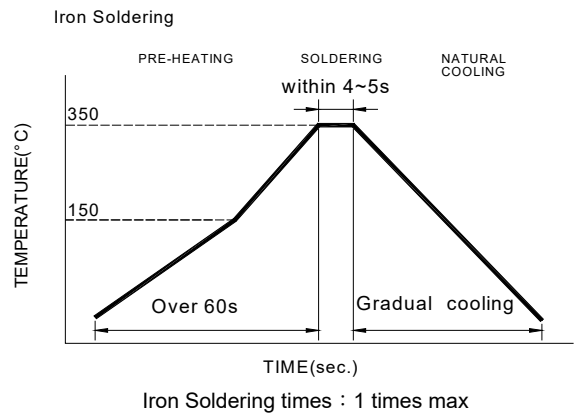

Table (1.1): Reflow Profiles

Profile Type:	Pb-Free Assembly
Preheat	
-Temperature Min(T_{smin})	150°C
-Temperature Max(T_{smax})	200°C
-Time(t_s)from(T_{smin} to T_{smax})	60-120seconds
Ramp-up rate(T_L to T_p)	3°C/second max.
Liquidus temperature(T_L)	217°C
Time(t_L)maintained above T_L	60-150 seconds
Classification temperature(T_c)	See Table (1.2)
Time(t_p) at $T_c - 5^\circ\text{C}$ (T_p should be equal to or less than T_c .)	< 30 seconds
Ramp-down rate(T_p to T_L)	6°C /second max.
Time 25°C to peak temperature	8 minutes max.

T_p: maximum peak package body temperature, **T_c**: the classification temperature.
For user (customer) **T_p** should be equal to or less than **T_c**.

Table (1.2) Package Thickness/Volume and Classification Temperature (T_c)

	Package Thickness	Volume mm ³ <350	Volume mm ³ 350-2000	Volume mm ³ >2000
PB-Free Assembly	<1.6mm	260°C	260°C	260°C
	1.6-2.5mm	260°C	250°C	245°C
	≥2.5mm	250°C	245°C	245°C

Reflow is referred to standard IPC/JEDEC J-STD-020E ◦

10. Packaging Information

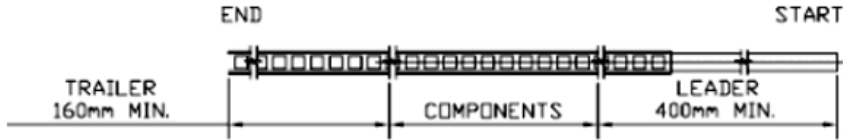

(1) Reel Dimension

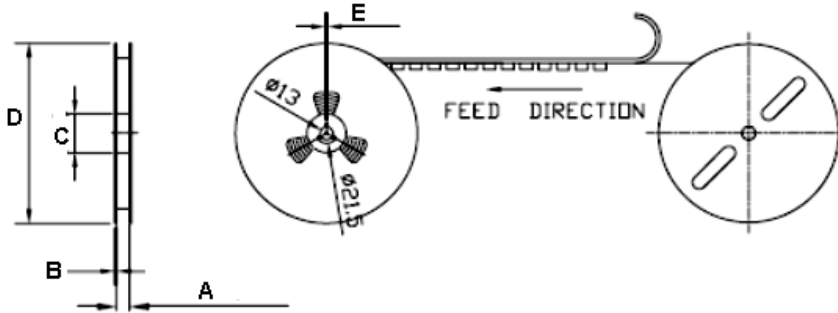

Type	A(mm)	B(mm)	C(mm)	D(mm)	E(mm)
LAP-17E241P7D8	33.5±2.0	2.0±0.15	φ 100	φ 330±2	2.5

(2) Tape Dimension

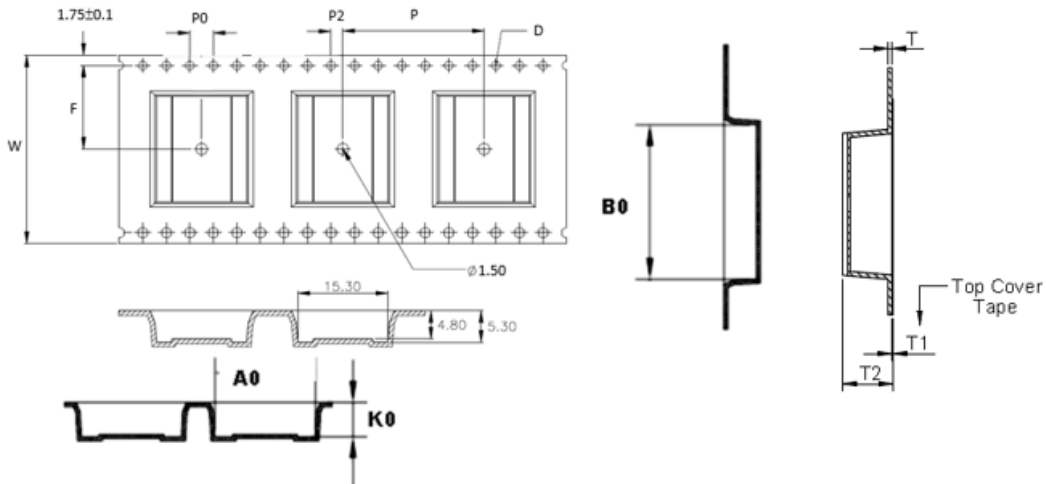

Series	Bo(mm)	Ao(mm)	Ko(mm)	P(mm)	Po(mm)	P2(mm)	W(mm)	F(mm)	D(mm)	T(mm)	T1(mm)	T2(mm)
LAP-17E241P7D8	17.93±0.1	15.3±0.1	4.80±0.1	24.0±0.1	4.0±0.1	2.0±0.1	32±0.3	14.2±0.1	1.5±0.1	0.4±0.05	0.06±0.01	5.6±0.1

(3) Packaging Quantity

LAN	LAP-17E241P7D8
Chip / Reel	400

Application Notice

- Storage Conditions(component level)
 - To maintain the solderability of terminal electrodes:
 - products meet IPC/JEDEC J-STD-020D standard-MSL, level 1.
 - Temperature and humidity conditions: Less than 40°C and 60% RH.
 - Recommended products should be used within 12 months form the time of delivery.
 - The packaging material should be kept where no chlorine or sulfur exists in the air.
- Transportation
 - 1. Products should be handled with care to avoid damage or contamination from perspiration and skin oils.
 - 2. The use of tweezers or vacuum pick up is strongly recommended for individual components.
 - 3. Bulk handling should ensure that abrasion and mechanical shock are minimized.