

# HC-49/US SMD TYPE



## Application of Crystal

- ▶ Best choice for mother board
- ▶ USB
- ▶ LAN card
- ▶ Router
- ▶ Switch



## Features

- ▶ Low cost
- ▶ Industry standard package
- ▶ High reliability and stability crystal
- ▶ Wide frequency range and calibration tolerances available
- ▶ RoHS compliant / Pb free



## Electrical Specification

NO	Model	HC-49/US SMD
1	Frequency Range	3.579545 ~ 100.000 MHz
2	Frequency Tolerance at 25°C±2°C	±10 ~ ±50 ppm (TYP.)
3	Frequency Stability Over Oper Temp Range	±10 ~ ±50 ppm (TYP.)
4	Operating Temp Range	-.10°C~ +60°C,-20°C~ +70°C or customer requirement
5	Load Capacitance	8 pF ~ 32 pF, series or special
6	Drive Level	0.1uW ~ 1000uW(TYP.: 100uW)
7	Insulation Resistance	500MΩ min / DC 100V±15V
8	Soldering Reflow Profile	255°C±10°C 8sec. max
9	Case Material	Low profile type
10	Oscillation Mode	Fundamental, 3rd overtone
	Measure Instrument	S&A 250B

## Equivalent Series Resistance(ESR) VS Frequency

NO	Frequency (MHz)	Oscillation Mode	HC-49US SMD
1	3.57 ~ 3.79	Fundamental	180Ω max.
2	3.8 ~ 4.49	Fundamental	150Ω
3	4.5 ~ 5.99	Fundamental	120Ω
4	6.0 ~ 7.99	Fundamental	100Ω
5	8.0 ~ 9.99	Fundamental	80Ω
6	10.0 ~ 11.99	Fundamental	70Ω
7	12.0 ~ 15.99	Fundamental	60Ω
8	16.0 ~ 19.99	Fundamental	50Ω
9	20.0 ~ 39.99	Fundamental	40Ω
10	26.0 ~ 39.99	3rd overtone	100Ω
11	40.0 ~ 70.0	3rd overtone	80Ω
12	70.0 ~ 100.0	3rd overtone	100Ω

Dimensions (mm):

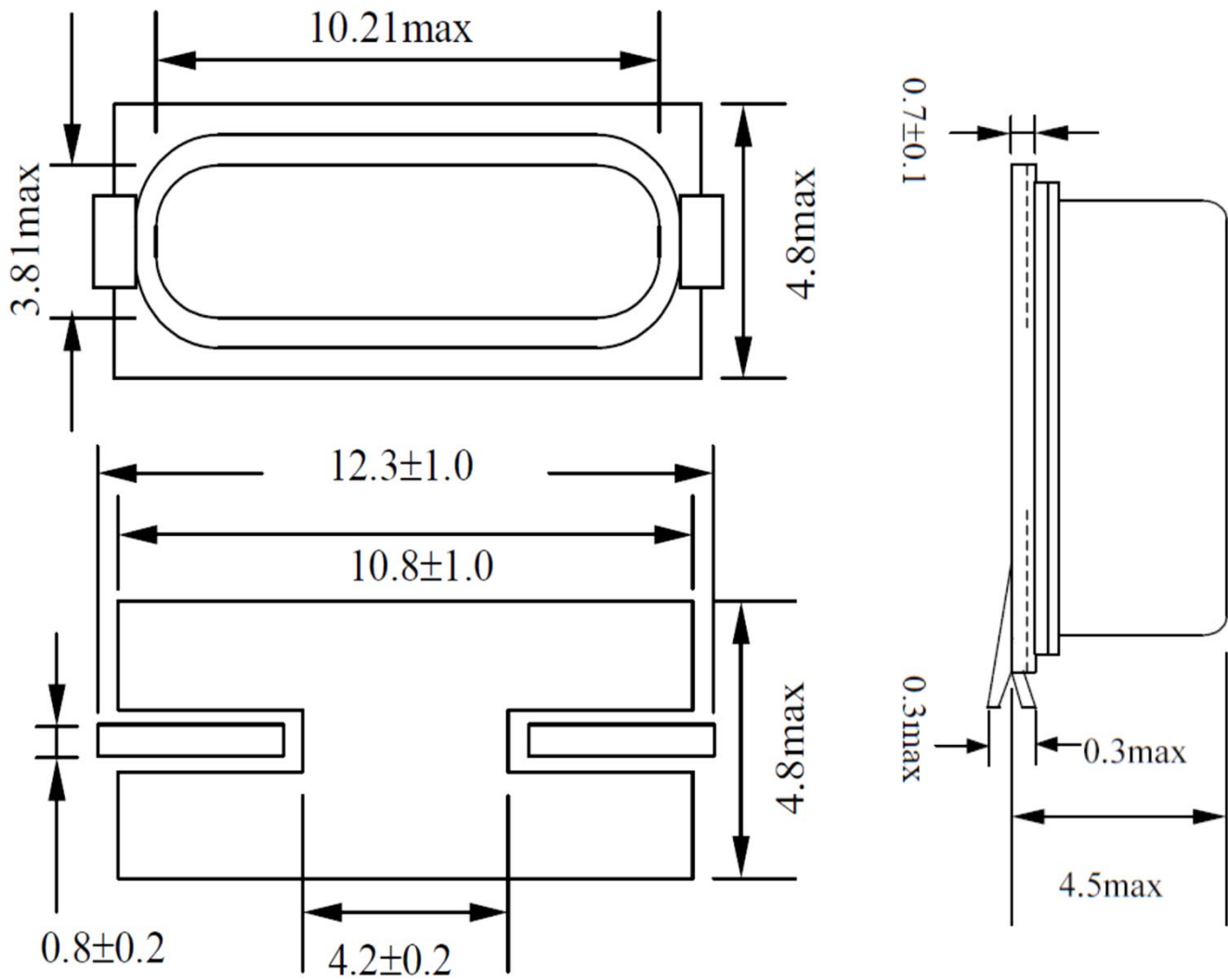

Land pattern (reference):

